

# HANDWORKER® GUARD KIT

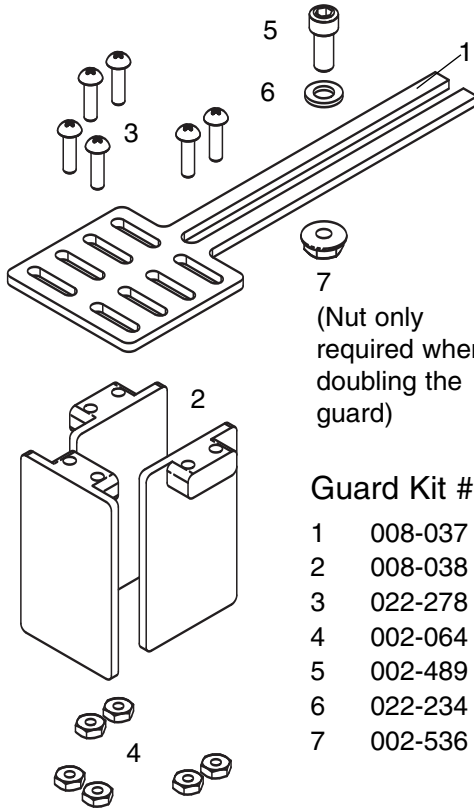

7  
(Nut only required when doubling the guard)

## Guard Kit #008-522

- |   |         |                    |
|---|---------|--------------------|
| 1 | 008-037 | Guard Support      |
| 2 | 008-038 | Guard Plate        |
| 3 | 022-278 | #8-32 X 5/8" RHMS  |
| 4 | 002-064 | #8-32 Hex Nut      |
| 5 | 002-489 | 1/4-20 X 5/8" SHCS |
| 6 | 022-234 | Washer             |
| 7 | 002-536 | 1/4-20 Lock Nut    |

Assemble guard kit as shown at left. Attach guard using the 5/8" bolt in the threaded hole located in the Tool Holder module (See Fig. #1). **NOTE:** For some tools, it may require that you cut the clear plastic Guard Plates to allow sufficient work access. Guard Plates can be cut with a bandsaw, jigsaw or a hack saw. Order extra Guard Plates below. Some long nose tools require longer guards. For these tools use a double guard as shown below in Fig. #2. Attach the second guard to the first guard as shown.

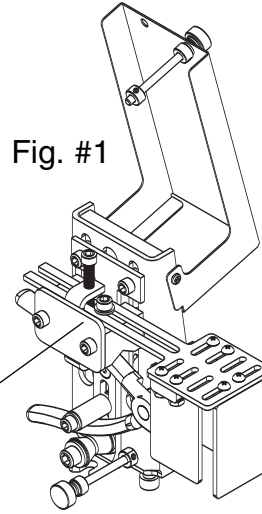

Fig. #1

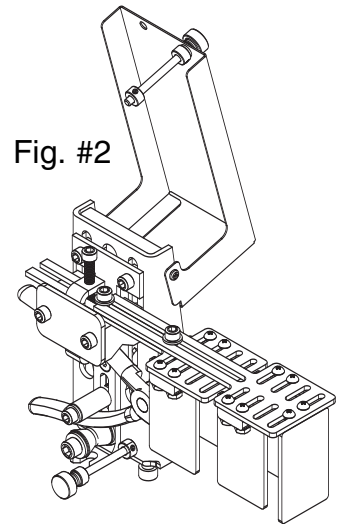

Fig. #2

TOOL HOLDER MODULE

QTY.	PART NO.	DESCRIPTION	COST EACH	Amount
	008-524	Set of 4 Guard Plates	\$ 8.95	
	008-522	Complete Guard Kit	\$ 29.00	

Prices subject to change without notice.

**TOTAL DUE:**

**Ship To:** Company \_\_\_\_\_

Name \_\_\_\_\_

Shipping Address \_\_\_\_\_

City \_\_\_\_\_

State \_\_\_\_\_

Zip \_\_\_\_\_

Phone: \_\_\_\_\_

**Shipping:** Enclose money order or personal check and receive free ground shipping in lower 48 states. Freight and handling costs will be charged to credit card orders.

Sent US Mail or UPS ground unless otherwise requested.

*Please send via:* \_\_\_\_\_

### METHOD OF PAYMENT:

- Check or Money Order  
(for personal check allow 7 days to process)
- Charge my account (listed firms only)
- MasterCard       Visa
- American Exp.       Discover

Card No. \_\_\_\_\_

Exp. \_\_\_\_\_ / \_\_\_\_\_

\_\_\_\_\_  
Your Signature

### MAIL ORDER TO:

HandWorker  
Glendo Corporation  
P.O. Box 1153  
Emporia, KS 66801

**FAX ORDER TO:** 620-343-9640

**ORDER TOLL FREE:**

**1-800-835-3519**

Monday - Friday / 8am-5pm Central Time  
PLEASE ASK FOR ORDER DESK